

GOT710A NEW

EN 50155 S3 10.4" XGA TFT LCD Railway Fanless Touchscreen Panel PC with Intel Atom® x6425E Processor (12W) 2.0 GHz (-40°C to +70°C)

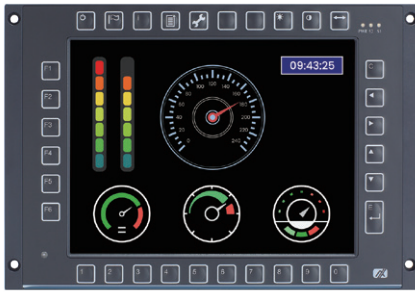

▲ Touch without keypad version

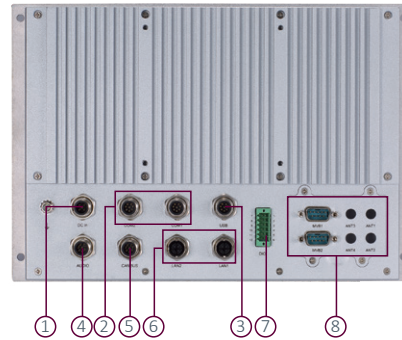

1. DC power input with isolation 1.5 kV
2. 2 x isolated RS-232/422/485
3. USB 2.0
4. Mic-in/Line-out
5. Isolated CAN bus
6. 2 x 2.5 GbE LAN
7. Isolated DIO (6-in/2-out)
8. Flexible I/O window



Fanless



Wide Temp.



Low Power



M12 Connector



DDR4



EN 50155

Features

- Sunlight readable 10.4" XGA TFT LCD
- Intel Atom® x6425E processor, 12W (Elkart Lake)
- Alternative keypad control on the front bezel
- M12-type lockable connectors design
- Auto-dimming for different environments
- Operating temperature ranges from -40°C to +70°C (EN 50155 OT4)
- Typical 24 to 110 VDC wide power input range, EN 50155 Class S3 20 ms power interruption protection
- EN 50155 and EN 45545-2 certified for railway applications

Introduction

The EN 50155 certified GOT710A features a 10.4-inch XGA TFT LCD display with a high brightness LED backlight. This enables train operators to effortlessly read operational status messages, even when exposed to direct sunlight. Designed for simplicity in operation and maintenance, this all-in-one railway touchscreen panel PC includes an alternative keypad control located on the front bezel for convenient access and cleaning. Additionally, boasting an IP65-rated front bezel and M12 connectors, this panel PC is well-suited for robust and reliable railway applications.

Wide Temperature (-40°C to +70°C)

The Intel Atom®-based GOT710A offers wide temperature range support and fanless operation. Additionally, it features a high brightness TFT LCD display and a compact design tailored for demanding transportation environments.



Introduction

Designed for Railway Applications

Axiomtek's GOT710A is specifically designed to meet the rigorous demands of human-machine interface (HMI) applications within the railway industry. It excels in tasks such as monitoring and controlling speed, temperature, security, and fleet management. To ensure dependable operation across diverse locations, this 10.4-inch railway panel PC offers versatile mounting options including wall mount and VESA mount. Additionally, it is compatible with Windows® 11 and Linux, providing flexibility and compatibility with various software systems.

Specifications

Front Bezel	IP65-rated aluminum front bezel and IP40-rated rear protection	
LCD Panel	Display Type	10.4" XGA TFT LCD
	Brightness (cd/m ²)	500 nits
	Resolution	1024 x 768
	Viewing Angle (H/V)	176°/176°
Main System	CPU	Intel Atom® x6425E processor, 12W (Elkart Lake)
	Chipset	SoC integrated
	System Memory	1 x 260-pin DDR4-3200 SO-DIMM, up to 32GB (default 4GB)
	BIOS	AMI
	Storage	1 x M.2 Key B 2242 SSD (default 128GB)
	Watchdog Timer	255 levels, 1 to 255 seconds
	Onboard Graphics	Integrated in Intel® GFX
I/O Connector	2 x M12 A-coded 8-pin isolated RS-232/422/485 2 x M12 X-coded 8-pin 2.5GbE LAN 1 x M12 A-coded USB 2.0 (2-port signal) 1 x M12 A-coded isolated DC-in 1 x M12 A-coded 8-pin Mic-in/Line-out 1 x terminal block isolated DIO (6-in/2-out) 1 x M12 A-coded 8-pin isolated CAN bus	
Expansion Interface	1 x full-size Mini Card slot (PCIe/USB/SIM) 1 x full-size Mini Card slot (PCIe/USB/mSATA) 1 x M12 Key B 2242 slot (SATA) 1 x M12 Key E 2230 slot (PCIe/USB)	
Flexible Window	MVB (optional)	
Touchscreen	Projected capacitive touch	
Power Supply	Typical 24 to 110 VDC EN 50155 Class S3 20 ms power interruption protection	
Dimensions (W x D x H)	310 x 55 x 214 mm (12.20" x 2.17" x 8.43") (Excluding connectors and fixation dimensions, please refer to below drawing to get more details)	
Packing Dimensions (W x D x H)	392 x 195 x 447 mm (15.43" x 7.68" x 17.60")	
Weight (net/gross)	2.69 kg (5.93 lbs)/4.17 kg (9.19 lbs)	
Operating Temperature	-40°C to +70°C (-40°F to +158°F) (EN 50155 OT4)	
Relative Humidity	10% to 90% relative humidity @ +40°C, non-condensing	
Certifications	CE/FCC Class A, EN 50155, EN 45545-2 certified, and UIC-612-01 Keypad layout complied	

* W.T.: Wide Temperature. All W.T. supported products have to be sorted by Axiomtek.

Ordering Information

GOT710A-ELK-TC (P/N: E22B710A00)	10.4" XGA railway fanless touchscreen panel PC with Intel Atom® x6425E, sunlight readable LCD (500 nits), projected capacitive touchscreen, 24 to 110 VDC power input, and EN 50155 Class S3 20ms power interruption protection, default with DDR4 4GB and M.2 SSD 128GB
GOT710A-ELK-TCK (P/N: E22B710A01)	10.4" XGA railway fanless touchscreen panel PC with Intel Atom® x6425E, sunlight readable LCD (500 nits), projected capacitive touchscreen, 24 to 110 VDC power input, and EN 50155 Class S3 20ms power interruption protection and keypad, default with DDR4 4GB and M.2 SSD 128GB

*Specifications and certifications may vary based on different requirements.



Packing List

1 x GOT710A unit
 1 x phoenix connector
 2 x M.2 slot screw M3 x 4L
 2 x PCIe Mini Card slot screw M3 x 5L

Optional Accessories

E29R318100	ACC318-501-203	LTE NL668-EAU kit
E29R301103	ACC301-701-203	Wi-Fi 5 QCNFA364A kit
594B8122820E	M12 A-coded USB cable	
594B7102100E	RS-232 cable	
594B7102700E	M12 X-coded LAN cable	
594B7100B00E	M12 DC-in power cable with ACC signal, length 1.8 m	
509000002200	PWS 9NA0908344 FSP 90W AC to DC (24V) adapter with M12 connector	
E39Q108103	CANBus module with 2DB9 for flexible window expansion	

Optional OS Installation

Windows® 11
 Ubuntu 22.04

Optional EOS Installation

Windows® 11 (IoT)

Dimensions

